

MARK J1 + J2  
FAR SIDE

MARKING FAR SIDE PER  
SPEC. A2626323 PARA  
3.1.3.

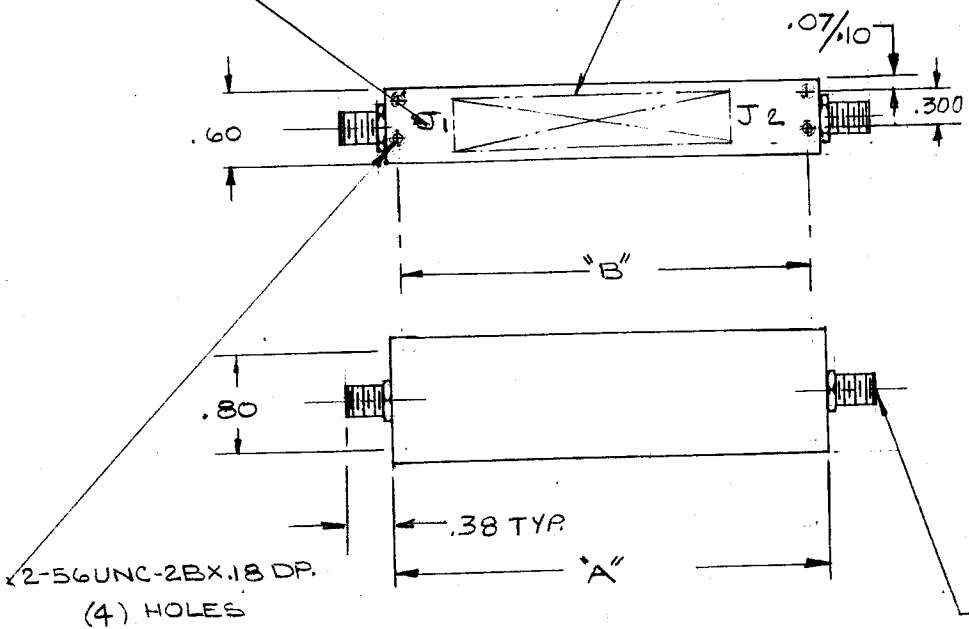

ZONE		LTR	ECN NO.	DESCRIPTION	DATE	APPROVED
		A	4055001-001	ADDED ±.030 TO DIM 1.00	9/10/84	EJC
D2		B	4055001-002	DIM. 300 WAS .275 ±.010 REMOVED DIM. 225 ±.010 ADD DIM. .07/10 AND ADDED ±.010 TOLERANCES TO 'B' DIM. ALSO DELETED MOUNTING FROM WIDE SURFACE; ADDED NOTE 2.	6/2/86	EJC
D3		C	4055001-003	REVISED LOCATION OF PART NO. MARKING	5-20-87	EJC

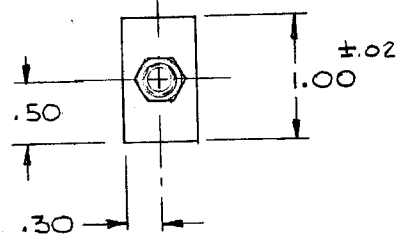

-3	3.50	3.30 ±.01
-2	4.40	4.20 ±.01
-1	6.00	5.80 ±.01
DIM.	'A'	'B'

NOTES:  
1. THIS DWG IS IN ACCORDANCE WITH ITTAV SPEC. 2626323  
2. MOUNTING THREADED INSERTS SHALL BE LOCKING HELICOIL TYPE OR EQUIV. END RELIEF, SHALL BE SUFFICIENT TO ALLOW MOUNTING TO USE .062 PLATE WITH A STD LENGTH MS 24693 SCREW.

UNLESS OTHERWISE SPECIFIED: DIMENSIONS ARE IN INCHES. AND INCLUDE FINISH. TOLERANCES ARE: FRACTIONS ± 1/64 DECIMALS .XX ± .01    .XXX ± .005 ANGLES ± 0°15' SURFACE FINISH 63 CONCENTRICITY .004 TIR		DRAWN	SIGNED	DATE	 <b>MICROWAVE COMPANY, INC.</b> 22 PARK PLACE, P.O. BOX 273 BUTLER, NEW JERSEY 07405 201-492-1207 FSCM 61453
PROPRIETARY DOCUMENT THIS DRAWING AND/OR INFORMATION ON SUBJECT MATTER CONTAINED HEREIN, SHALL NOT BE USED, COPIED OR DISSEMINATED IN ANY MANNER OR FOR ANY PURPOSE, OTHER THAN AS EXPRESSLY STATED BY RS MICROWAVE COMPANY INC.		CHECKED	E.E. APP'D	M.E. APP'D	
NEXT ASSY		USED ON		Q.A. APP'D	
				JOB NO.	
		TITLE		BANDPASS FILTER	
		SIZE	CODE IDENT. NO.	DWG. NO.	REV.
		B	61453	4055001-( )	C
		SCALE		SHEET OF	